

**ACCESS PANEL**

**CODE GL100**

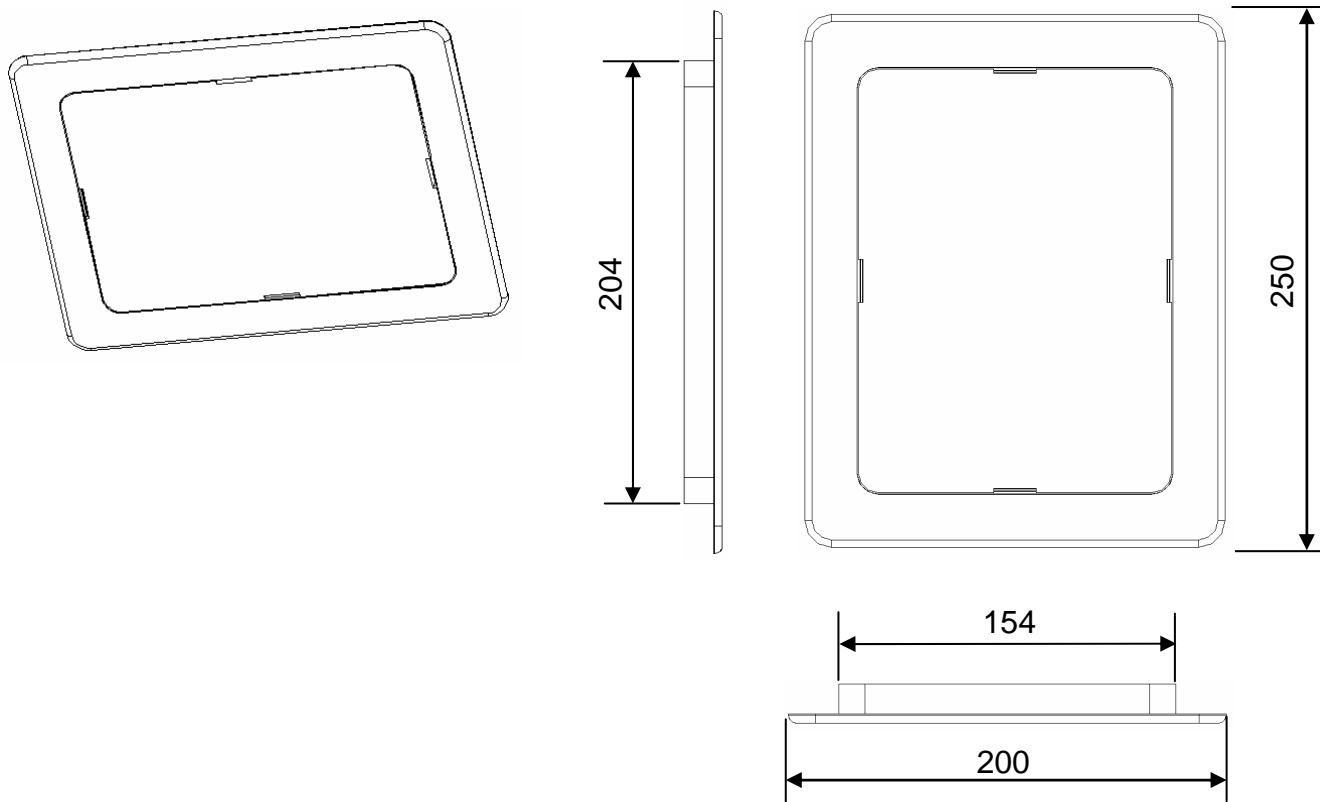

### Description:

The GL100 Access Panel provides easy access to building services in walls. The panel is predominantly used in domestic household situations for access to i.e.: -

- An electrical wiring system
- Fuse Boxes / Switches
- Controls / Connection Links
- Valves / Stopcocks / Plumbing

The product is lightweight, easy to fit and is manufactured from High Impact Polystyrene (HIPS). This then allows for a smooth textured finish to the panel that can then be painted over if required.

The GL100 also has a fully detachable door for easy and convenient access.

PACKING DETAILS	Individually packaged in polythene bag 20 per box
MATERIAL	HIPS
WEIGHT	3.6kg per box
COLOUR	White

MANTHORPE BUILDING PRODUCTS LTD  
MANTHORPE HOUSE  
BRITAIN DRIVE  
CODNOR GATE BUSINESS PARK  
RIPLEY  
DERBYSHIRE DE5 3ND

TEL: 01773 514 200  
FAX: 01773 514 262  
EMAIL: [sales@manthorpe.co.uk](mailto:sales@manthorpe.co.uk)  
WEB: [www.manthorpe.co.uk](http://www.manthorpe.co.uk)

DRN M.A

Date 28.04.04

DRG No

Issue

The company maintains a policy of continuous development of its product range and reserves the right to amend the specification without notice.

**MBP 8207**

**B**